

BODYCRAFT

F660 HIP SLED OWNER'S MANUAL

Serial Number Location

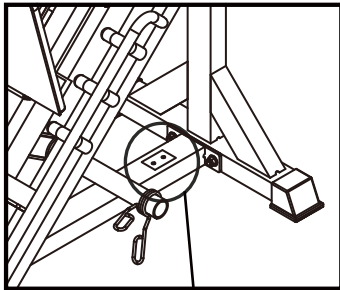

Record your Serial number
and purchase date here:

S/N _____

DATE: _____

DEALER: _____

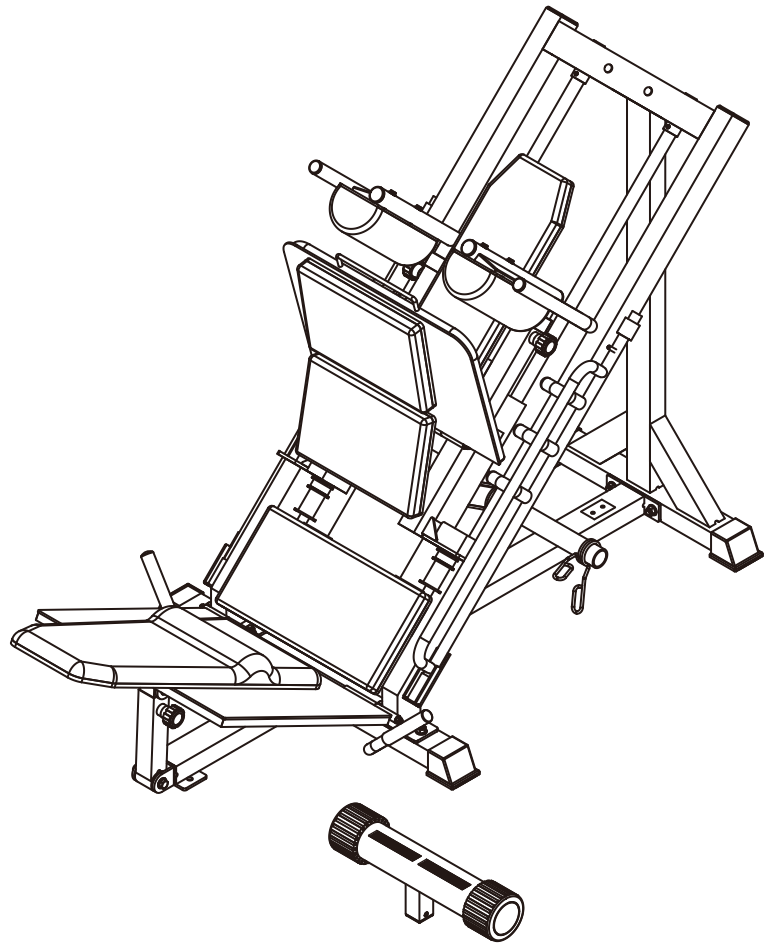

Model No. F660
MA409
BODYCRAFT

Fitness Authority Industrial Co., LTD.
No. 15, Xiangxue Rd., Dali Dist.,
Taichung City 41275, Taiwan.

Congratulations and Thank You!

Thank you for selecting the **BODYCRAFT F660 HIP SLED**. The **BODYCRAFT F660 HIP SLED** offers an impressive array of strength training exercises to develop every major muscle group of the body. Whether your goal is cardiovascular fitness, a shapely, toned body or dramatic muscle size and strength, the **BODYCRAFT F660 HIP SLED** will help you achieve the results you want. For your safety and benefit, read this manual and the accompanying literature before using the **BODYCRAFT F660 HIP SLED**. Keep this manual for future reference. If you have additional questions, please call your local **BODYCRAFT F660 HIP SLED** Dealer.

www.ibodycraft.com

Important Safety Notes

There is a risk assumed by individuals who use this type of equipment. Before beginning this or any other exercise program consult your physician. This is especially important for individuals over the age of 35 or persons with preexisting health problems. Recreation Supply, Inc. assumes no responsibility for personal injury or property damage sustained by or through use of this product.

- 1. This product must be assembled on a flat, level surface to assure its proper function.**
- 2. Clean pads and frame on a regular basis. We recommend warm, soapy water. Do not use harsh or abrasive chemicals.**
- 3. Inspect and tighten all parts before every use. Replace any worn parts immediately. Failure to do so may result in serious injury.**
- 4. Keep children away from the BODYCRAFT F660 HIP SLED at all times.**
- 5. Keep your hands away from cables and pulleys during operation.**
- 6. Keep your hands away from moving parts other than the designated handles.**
- 7. Make certain all cables are seated within the pulleys before every use.**
- 8. Exercise with care to avoid injury.**
- 9. If you are unsure about the proper use of the BODYCRAFT F660 HIP SLED call your local BODYCRAFT dealer or our customer service department.**

QUESTIONS?

As a quality exercise equipment supplier we are committed to your complete satisfaction. If you have questions, or find missing or damaged parts, we will guarantee your complete satisfaction through our authorized dealer service centers or our home office customer service department. Please call your local dealer.

www.ibodycraft.com

Gym Placement Planner

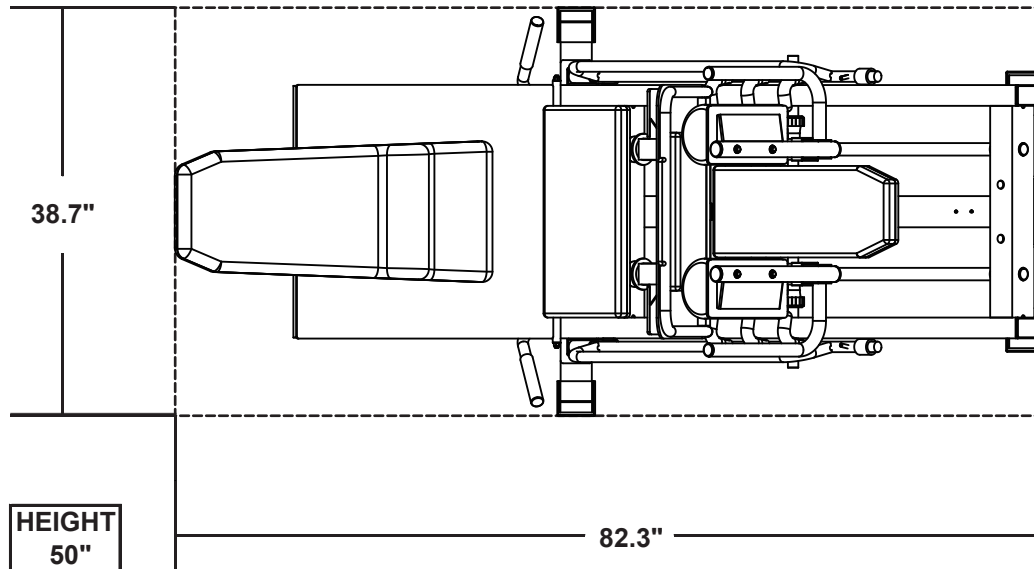

Recommended Tools for Assembly

Ratchet
9/16" Socket
3/4" Socket
9/16" Combination Wrench
3/4" Combination Wrench
Adjustable Wrench
Rubber Mallet
Metric Allen Key Set

Important Notes and Tips:

1. Do not tighten bolts until instructed.
2. Two people are required for the safe assembly of this product.
3. Use window cleaner or water to assist with sliding roller pads on to tubes.
4. Apply silicone lubricant onto guide rods prior to weight plate installation.
5. Please allow plastic parts to acclimate to room temperature before installation or they may be damaged.
6. Carefully install plastic caps using a rubber mallet.
7. When measuring bolt lengths, only measure the shank, as shown below.

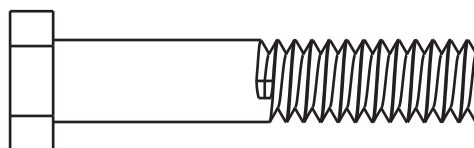

i.e. 2-1/4" Hex Bolt

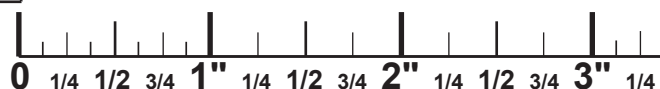

F660 PARTS LIST 1



NOTE: If you are missing a listed part, it likely has been pre-installed in our factory for quality control purposes. Please continue with assembly.

*Parts images are not to scale.

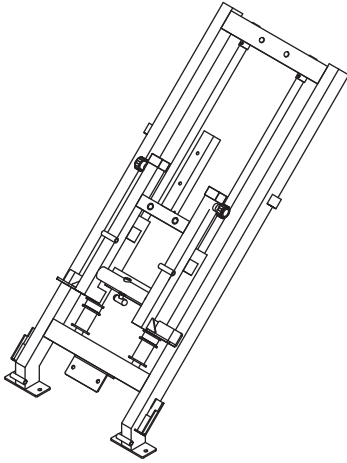

(1) MAIN FRAME

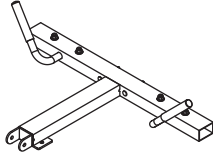

(2) FRONT STABILIZER

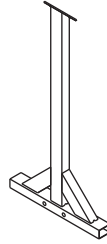

(3) REAR UPRIGHT

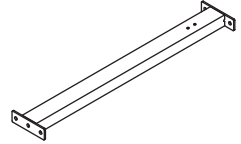

(6) BASE CONNECTOR



(7) RIGHT SHOULDER ASSEMBLY

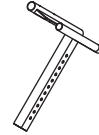

(8) LEFT SHOULDER ASSEMBLY

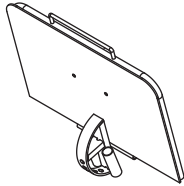

(9) LEG PRESS PLATE

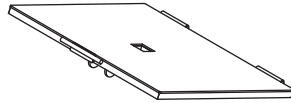

(10) FOOT PLATFORM

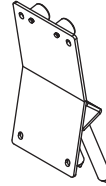

(11) HIP PAD PLATE

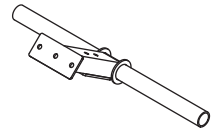

(12) WEIGHT HOLDER

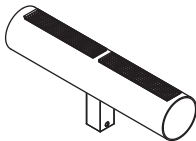

(13A) CALF BLOCK



(14) WEIGHT HOLDER SUPPORT

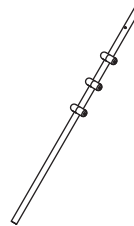

(15) RIGHT SAFETY STOPPER

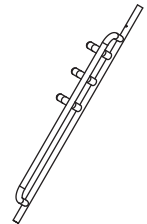

(16) LEFT SAFETY STOPPER

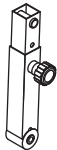

(17) FOOT PLATFORM ADJUSTER SLEEVE



(19) METAL HINGE

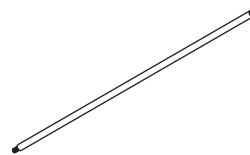

(20) FOOT PLATFORM AXLE

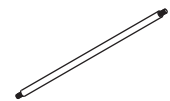

(21) FOOT PLATE AXLE

F660 PARTS LIST 2



NOTE: If you are missing a listed part, it likely has been pre-installed in our factory for quality control purposes. Please continue with assembly.

*Parts images are not to scale.



(25) SPRING CLIP

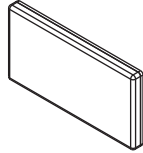

(26) SEAT PAD

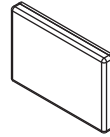

(27) BACK AND HIP PAD X 3pcs

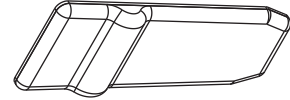

(28) BACK SUPPORTER PAD



(29) BACK PAD



(30) RIGHT SHOULDER PAD



(31) LEFT SHOULDER PAD

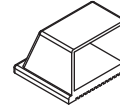

(32) 50 X 75mm END CAP X 4pcs



(33) 45 X 45mm SQ. CAP

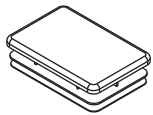

(34) 75 X 50mm END PLUG X 2pcs



(35) 38mm ROUND PLUG X 4pcs



(36) 31mm ROUND PLUG X 2pcs

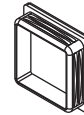

(67) 50 X 50mm SQ. CAP



(69) 75mm ROUND END CAP X 2pcs

NO.	DESCRIPTION	QTY.
45	1/2" X 3-1/2" HEX BOLT	2
46	1/2" X 3-1/4" HEX BOLT	1
47	1/2" X 3" HEX BOLT	1
48	5/16" X 2-1/4" SCREW	4
49	3/8" X 2-3/4" HEX BOLT (ALL)	2
50	3/8" X 1" INNER HEX SCREW	10
55	1/2" WASHER	7
56	3/8" WASHER	10
59	1/2" NYLON NUT	3
61	5/16" SPRING WASHER	4
62	6mm HEX KEY	1
63	4mm HEX KEY	1

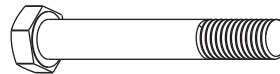

45



49



55

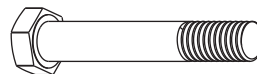

46



50



56

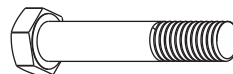

47



48



59



61

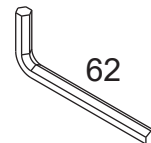

62

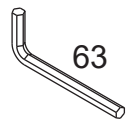

63

STEP 1 Base Frame Assembly

To ease the assembly process, do NOT tighten bolts until instructed.

Assembly requires two people.

1. Attach the Base Connector (6) to the Bolts welded on the Front Stabilizer (2) using two 1/2" Washers (55) and two 1/2" Nylon Nuts (59).
2. Attach the Base Connector (6) to the Bolts welded on the Rear Upright (3) using two 1/2" Washers (55) and two 1/2" Nylon Nuts (59). Slide the two 50 X 75 mm End Caps (32) onto the Front Stabilizer (2) and the Rear Upright (3).
3. Attach the pre-assembled Main Frame (1) to the vertical bolts welded on the Front Stabilizer (2) using two 1/2" Washers (55) and two 1/2" Nylon Nuts (59). Attach the Rear Upright (3) to the bolts welded to the top of the Main Frame (1) using two 1/2" Washers (55) and 1/2" Nylon Nuts (59). Slide the two 75 X 50 mm End Caps (34) onto the Main Frame (1).
4. Slide the 50X50 mm Sq Cap (67) onto the Linear Bearing Assembly (4).

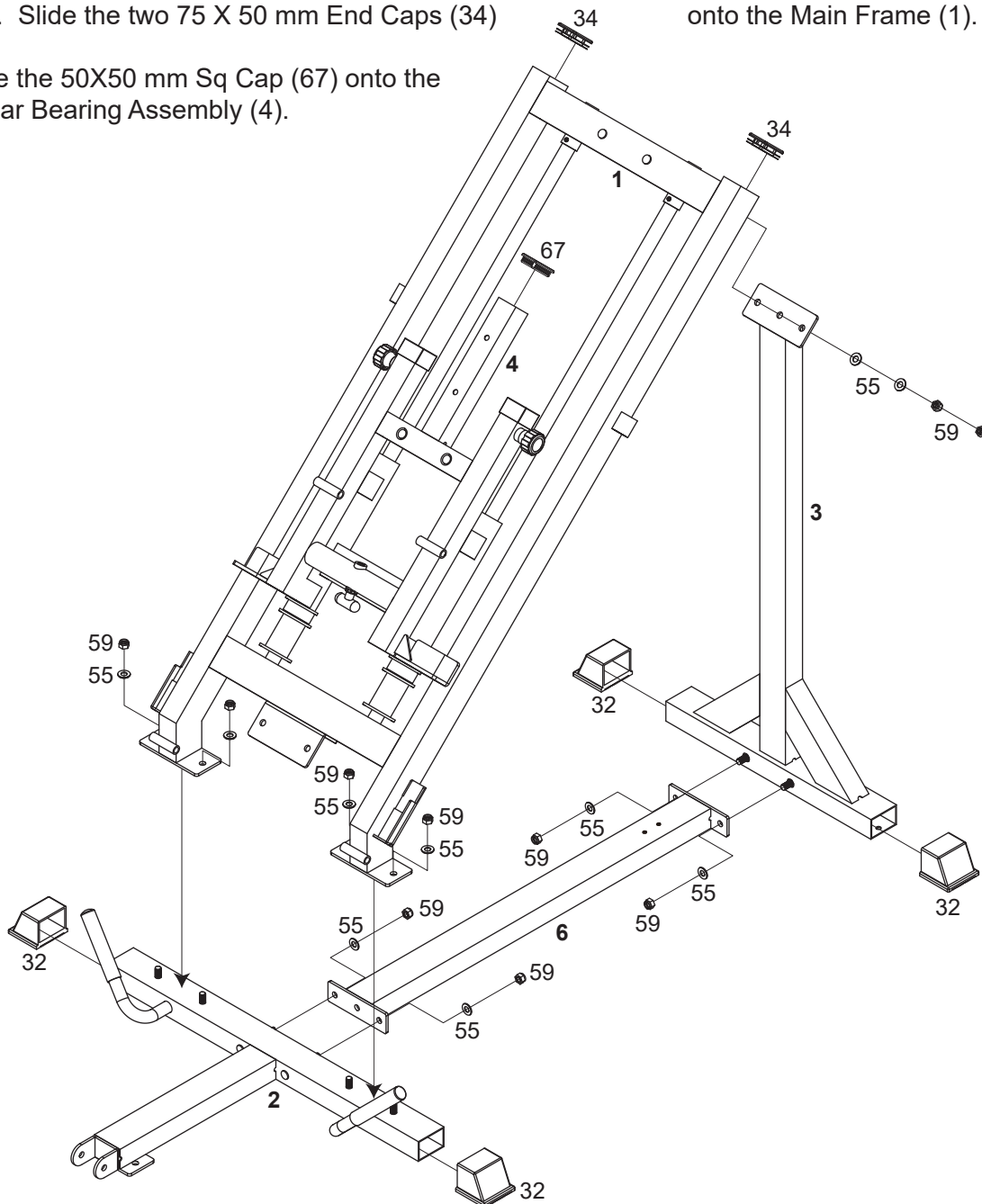

STEP 2 Shoulder Pads, Safety Stoppers, and Weight Holder Assembly

1. Attach the Weight Holder Support (14) to the Weight Holder (12) using one 1/2" X 3-1/4" Hex Bolt (46), two 1/2" Washers (55), and one 1/2" Nylon Nut (59) on the top hole of the Weight Holder (12) and one 1/2" X 3" Hex Bolt (47) at the bottom threaded hole.
2. Attach the Weight Holder Assembly (12 & 14) to the bolts welded to the underside of the Linear Bearing Assembly (4) and tighten with four 1/2" Washers (55) and four 1/2" Nylon Nuts (59).
3. Insert the top end of the Right Safety Stopper (15) into the top bracket on the Main Frame (1) and then slide the bottom end into the low bracket on Main Frame (1). Check to make sure the Safety Stopper rotates and slides freely. Insert an 8mm Locking Pin (24) into the hole on the top of the Right Safety Stopper (15). Tap the Locking Pin with a hammer to make sure it is permanently attached. Repeat the procedure for the Left Safety Stopper (16).
4. Attach two 38mm Round Plugs (35) to the top on both Shoulder Assemblies (7, 8). Attach one 31 mm Round Plug (36) to the handles at the top on both Shoulder Assemblies (7, 8).
5. Pull the Spring Knob (43) on the right side of the Linear Bearing Assembly (4) and insert the Right Shoulder Assembly (7). Attach the Right Shoulder Pad (30) to Right Shoulder Assembly (7) using two 5/16" X 2-1/4" Screws (48) and two 5/16" Spring Washers (61). Repeat the same procedure for the Left Shoulder

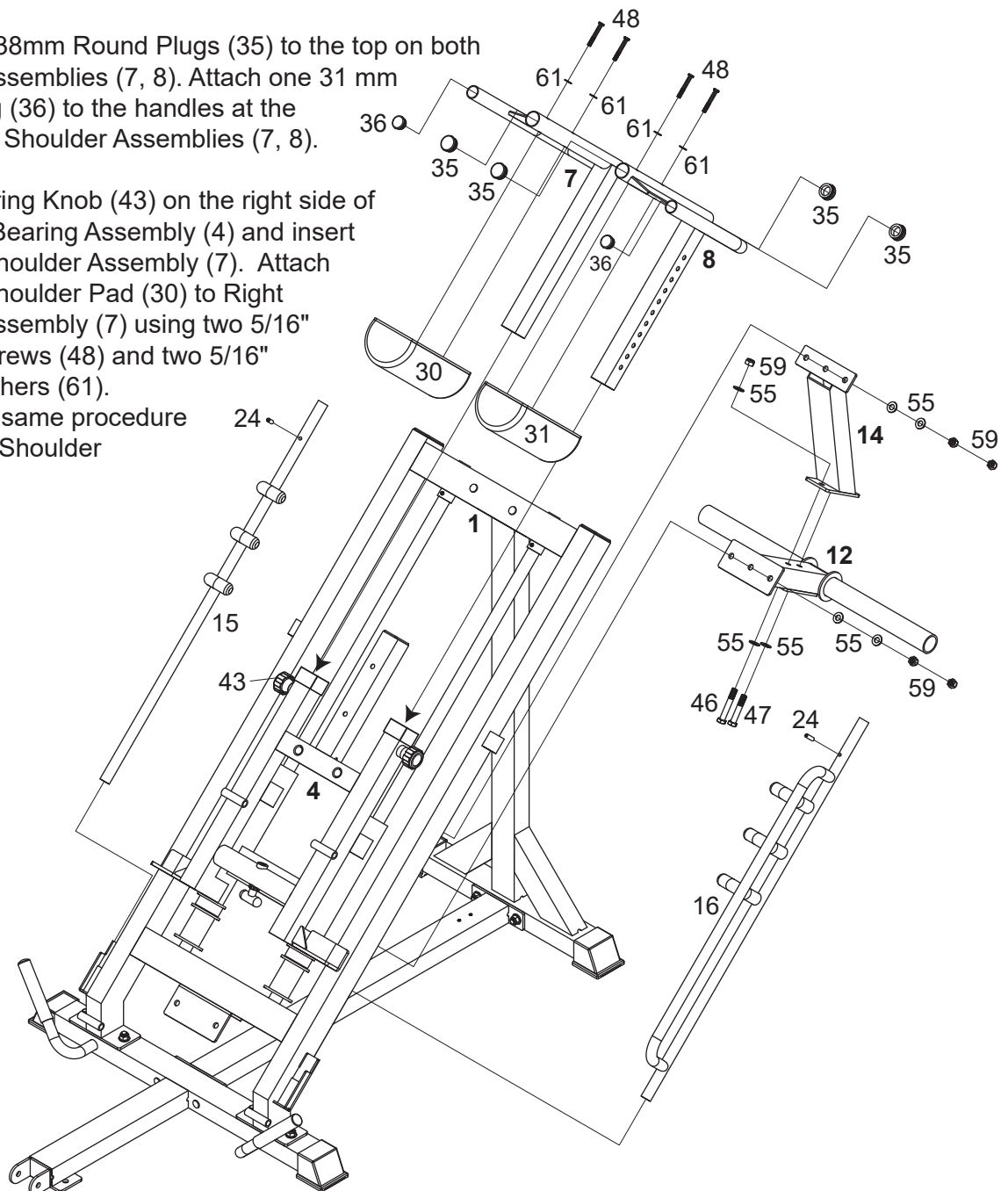

STEP 3 Leg Press Plate and Foot Platform Assembly

1. Attach the bottom side of the Foot Platform (10) to the Main Frame (1) by aligning the holes and then inserting the solid Foot Platform Axle (20). Attach a 3/8" Nut (60) to each side of the Foot Platform Axle (20).
2. Find the Foot Platform Adjuster Sleeve (17). Pull the Spring Knob (43) and insert the Foot Platform Adjuster Inside Tube (18). Attach the Foot Platform Adjuster Sleeve (17) to the Front Stabilizer (2), using one 1/2" X 3-1/2" Bolt (45), two 1/2" Washers (55) and one 1/2" Nylon Nut (59).
3. Attach the Foot Platform Adjuster Inside Tube (18) to the Foot Platform (10) using one 1/2" X 3- 1/2" Bolt (45), two 1/2" Washers (55), and one 1/2" Nylon Nut (59).
4. Attach a Back Pad (27) to the Leg Press Plate (9) using two 3/8" X 1" Hex Screws (50). Attach the Leg Press Plate (9) to the Linear Bearing Assembly (4) by aligning the holes and then inserting the solid Foot Plate Axle (21). Secure with a 3/8" Nut (60) on both sides. Pull the Pop Pin (44) on the Linear Bearing Assembly (4) to adjust the Leg Press Plate (9) to your desired angle.

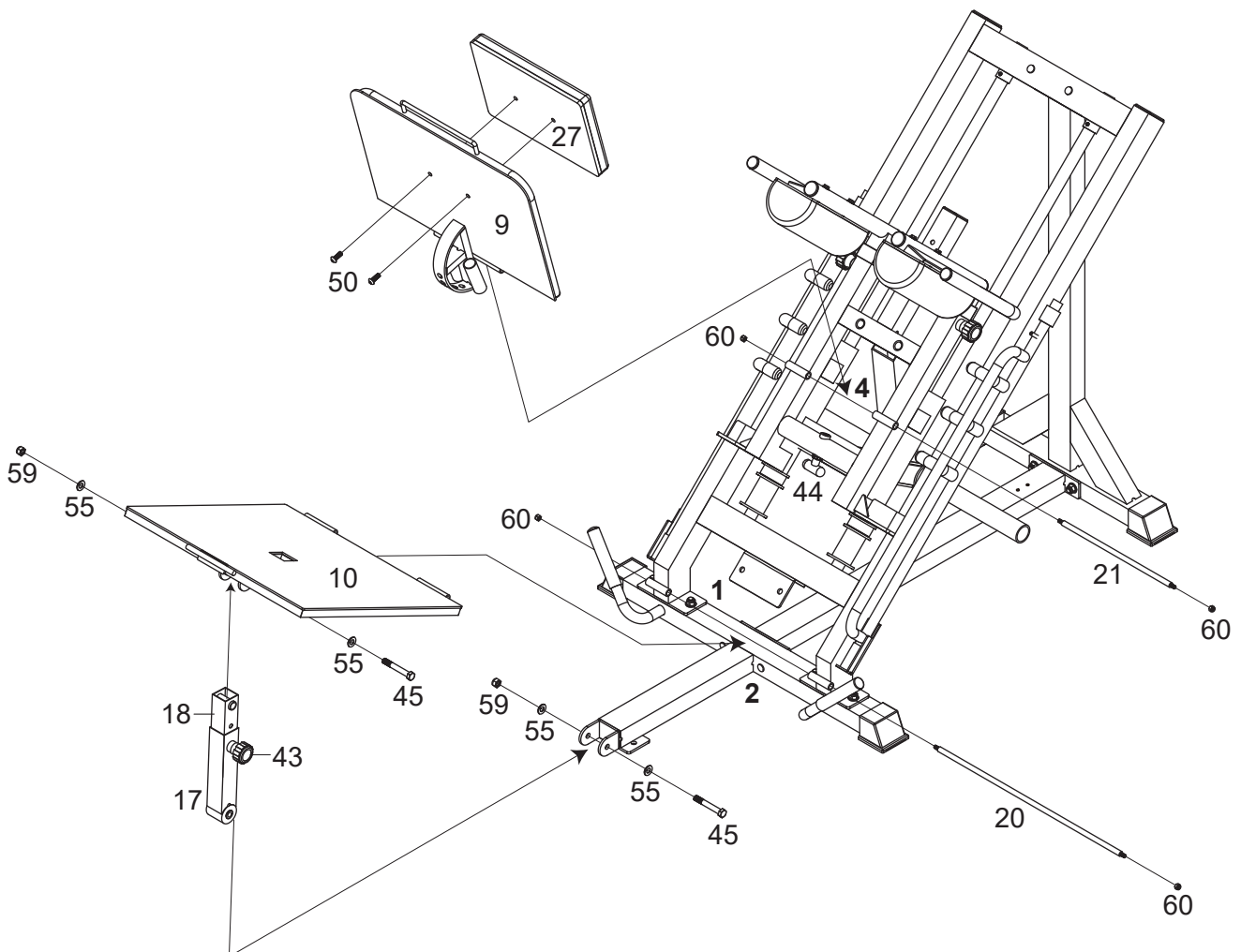

STEP 4 Back Pad Assembly

1. Adjust the Leg Press Plate (9) to the flat position and then attach the Back Pad (29) to the Linear Bearing Assembly (4) using two 3/8" X 2-3/4" Hex Bolts (49) and two 3/8" Washers (56).
2. Attach two Back Pads (27) to Hip Pad Plate (11) using four 3/8" X 1" Hex Screws (50) and two 3/8" Washers (56).
3. Slide the two Metal Hinges (19) onto the small axles welded to the top of the Foot Platform (10) and then attach the Back Pad (28) to the Metal Hinges (19) using two 3/8" X 1" Hex Screws (50) and two 3/8" Washers (56).
4. The Spring Clips (25) are used to hold the weight plates on the Weight Holder (12).

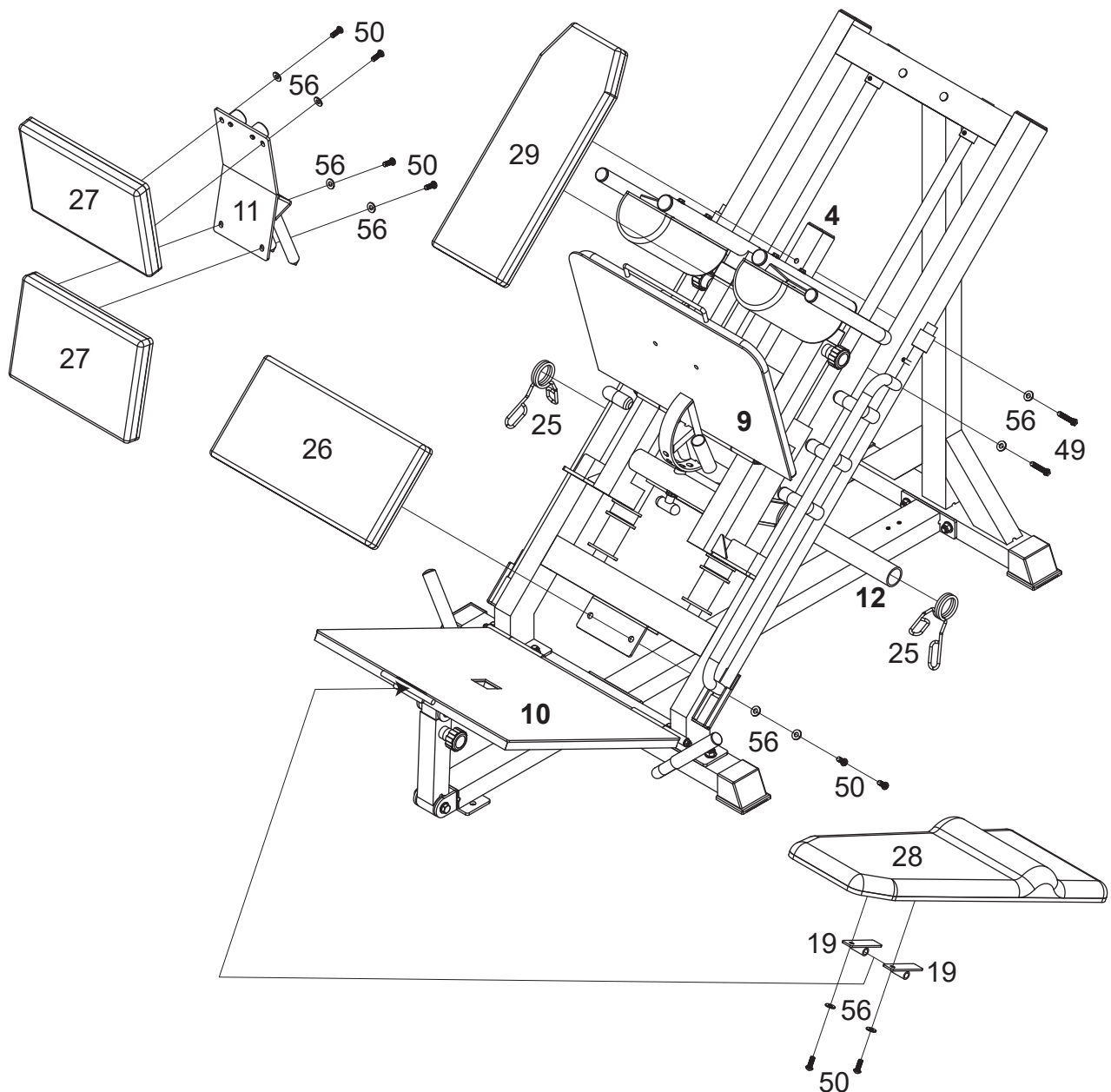

STEP 5 Calf Raise Assembly

1. Attach one 50mm End Plug (33) and two 75mm Round End Caps (69) to the Calf Block (13A). To perform calf raises, insert the Calf Block into the central hole in the Foot Platform (10).
2. Attach Back Pad Assembly (27) to the Leg Press Plate (9).

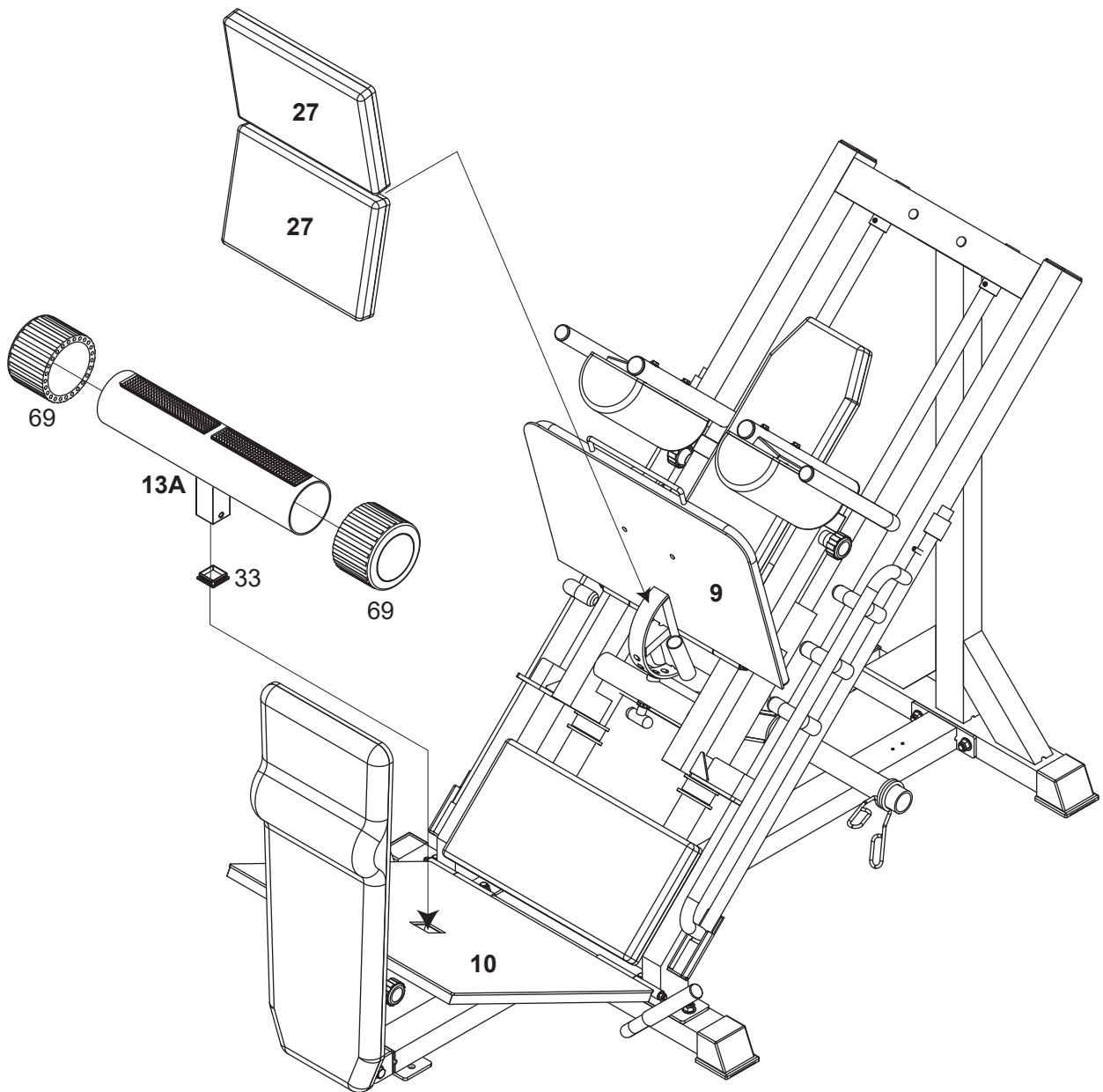

PARTS LIST

NO.	DESCRIPTION	QTY.
1	MAIN FRAME	1
2	FRONT STABILIZER	1
3	REAR UPRIGHT	1
4	LINEAR BEARING ASSEMBLY	1
5	SOLID GUIDE ROD	2
6	BASE CONNECTOR	1
7	RIGHT SHOULDER ASSEMBLY	1
8	LEFT SHOULDER ASSEMBLY	1
9	LEG PRESS PLATE	1
10	FOOT PLATFORM	1
11	HIP PAD PLATE	1
12	WEIGHT HOLDER	1
13A	CALF BLOCK	1
14	WEIGHT HOLDER SUPPORT	1
15	RIGHT SAFETY STOPPER	1
16	LEFT SAFETY STOPPER	1
17	FOOT PLATFORM ADJUSTER SLEEVE	1
18	FOOT PLATFORM ADJUSTER INSIDE TUBE	1
19	METAL HINGE	2
20	FOOT PLATFORM AXLE	1
21	FOOT PLATE AXLE	1
22	PLASTIC CAP	6
23	HAND GRIP	2
24	8mm LOCKING PIN	2
25	SPRING CLIP	2
26	SEAT PAD	1
27	BACK AND HIP PAD	3
28	BACK SUPPORTER PAD	1
29	BACK PAD	1
30	RIGHT SHOULDER PAD	1
31	LEFT SHOULDER PAD	1
32	50 X 75mm END CAP	4
33	45 X 45mm SQ CAP	1
34	75 X 50mm END PLUG	2
35	38mm ROUND PLUG	4
36	31mm ROUND PLUG	2
37	25mm ROUND PLUG	2

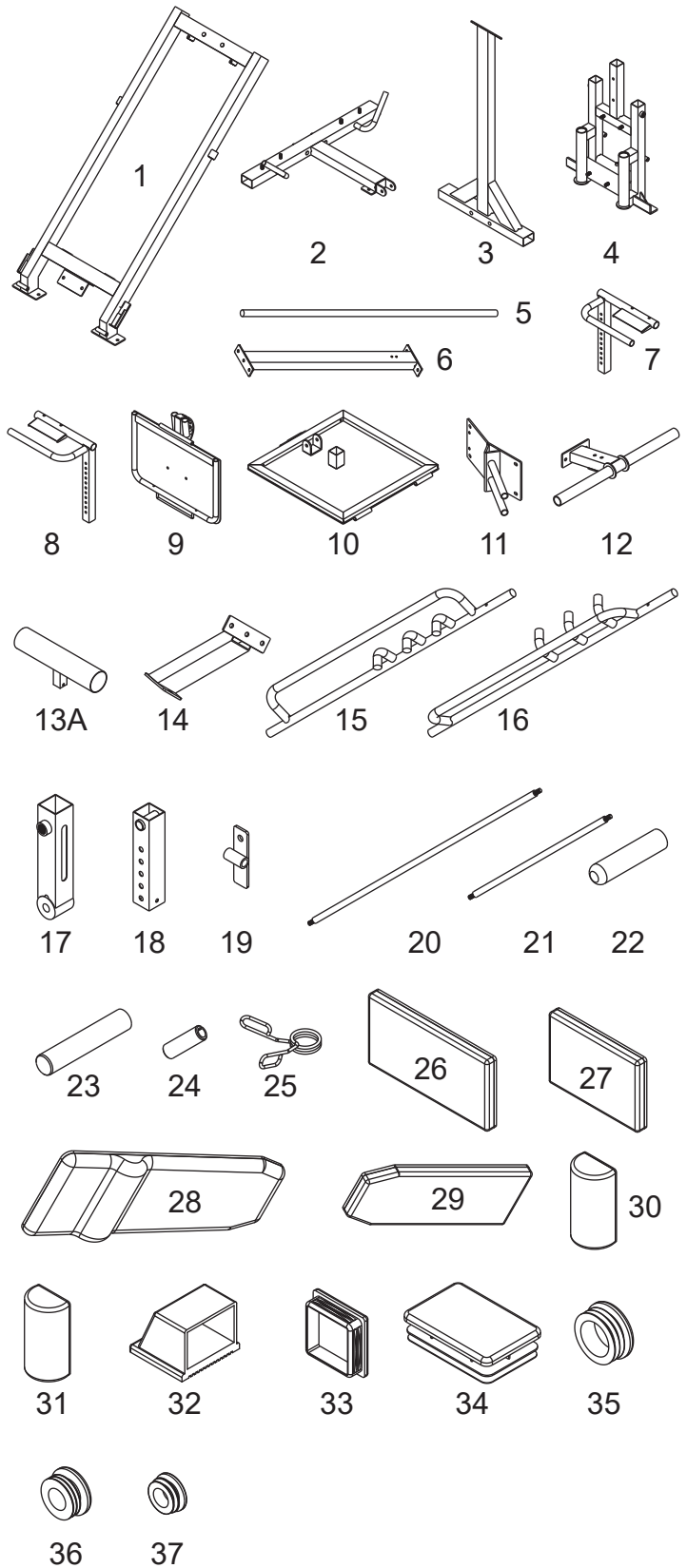

PARTS LIST

NO.	DESCRIPTION	QTY.
38	50 X 55mm PLASTIC SLEEVE	2
39	1/2" X 18mm BUSHING	4
40	LINEAR BEARING	4
41	RUBBER BUMPER	2
42	PLASTIC STUD	3
43	SPRING KNOB	3
44	POP PIN	1
45	1/2" X 3-1/2" HEX BOLT	2
46	1/2" X 3-1/4" HEX BOLT	1
47	1/2" X 3" HEX BOLT	1
48	5/16" X 2-1/4" SCREW	4
49	3/8" X 2-3/4" HEX BOLT (ALL)	2
50	3/8" X 1" INNER HEX SCREW	10
51	3/8" X 1/2" INNER HEX SCREW	3
52	ALLEN BOLT	1
53	M8 X 30mm DOME BOLT	2
54	5/16" X 1/4" SET SCREW	2
55	1/2" WASHER	21
56	3/8" WASHER	10
57	φ 10mm X 16mm WASHER	2
58	SPRING CLIP	4
59	1/2" NYLON NUT	17
60	3/8" NYLON NUT	4
61	5/16" SPRING WASHER	4
62	6mm HEX KEY	1
63	4mm HEX KEY	1
64	FOAM TUBE	2
65	42mm ROUND PLUG	2
66	NON SLIP	2
67	50 X 50mm SQ CAP	1
69	75mm ROUND END CAP	2
70	4" STACK SPACE	2
71	RUBBER CAP	2

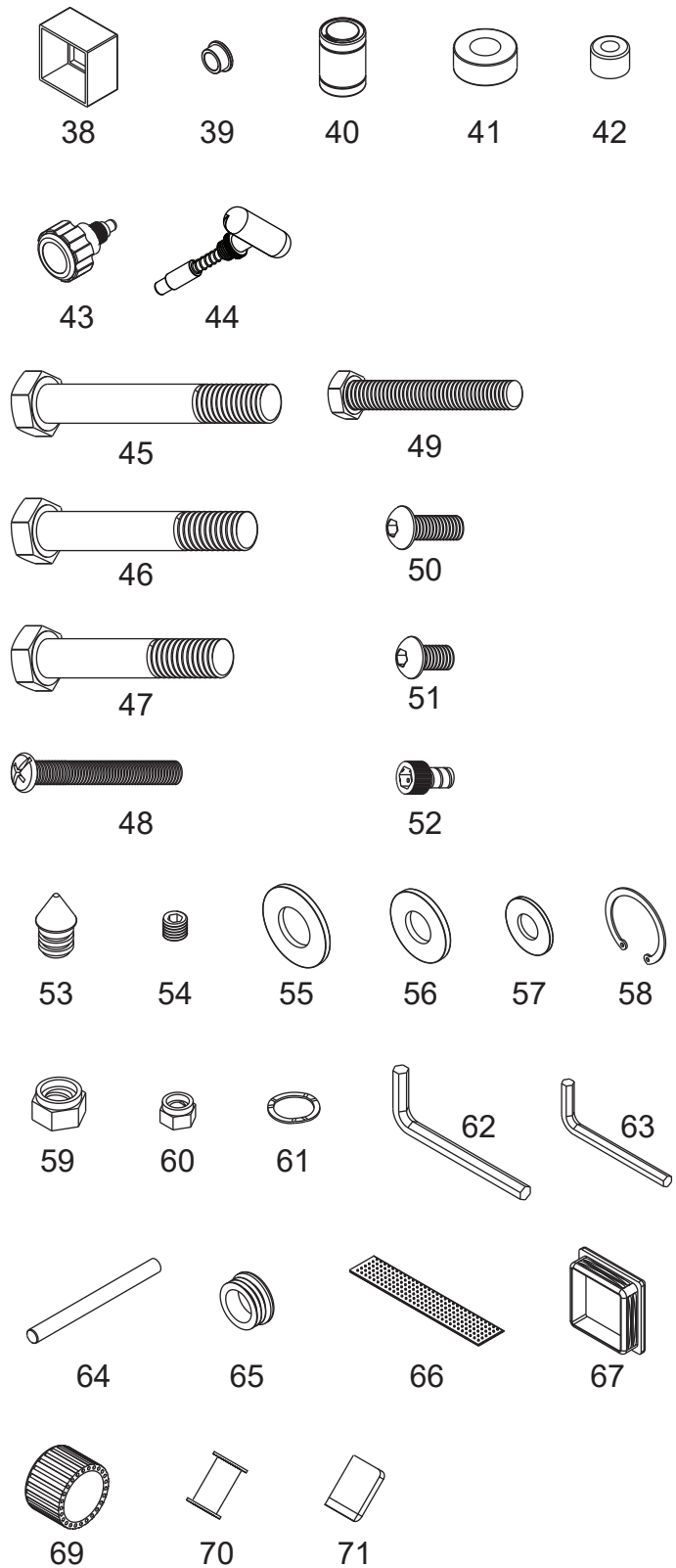

OVERVIEW

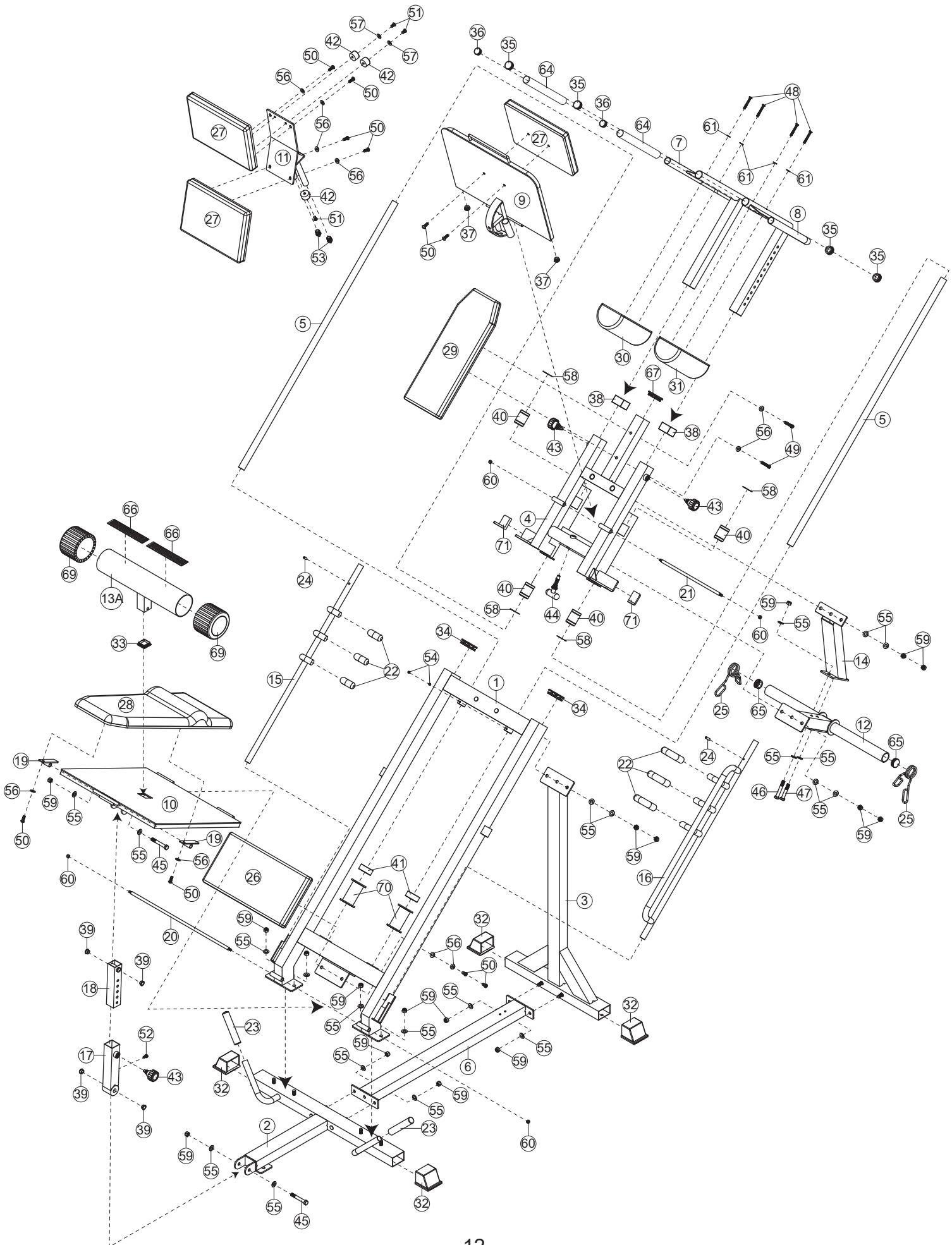

Assembly is complete! Please take the following steps before using the gym:

1. Make certain all bolts are tightened securely.
2. For better performance, apply a household lubricant (such as silicone) to any adjustable areas and to the Linear Bearing Assembly(4).
3. Enjoy many years of a Fit Lifestyle.

Thank you for purchasing the BODYCRAFT F660 HIP SLED!
If You have any questions or comments, please contact your
local BODYCRAFT dealer. www.ibodycraft.com